

Cat. No. S1/0 Style No. 1

■ Drill, Enlarge, or Modify Mounting Holes

- 1) Increase hole(s) dia. to 13/32 bolt.
- 2) Move location of mounting hole(s)
- 3) If buying blank lug, put custom hole(s) in.

IHI UL/CSA Installation Guide to Drill or Enlarge Mounting Holes:

<https://lugsdirect.com/PDF Documents/IHI-MTG-HOLE-FIELD-MODS-UL&CSA-CERTIFICATIONS.pdf>

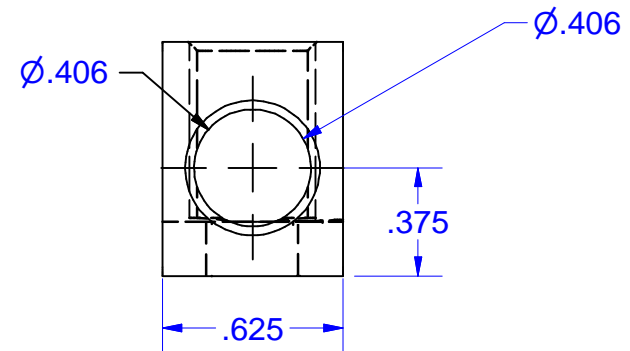
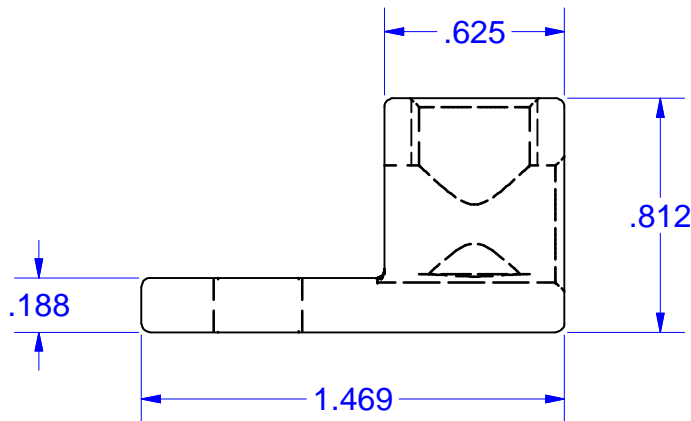
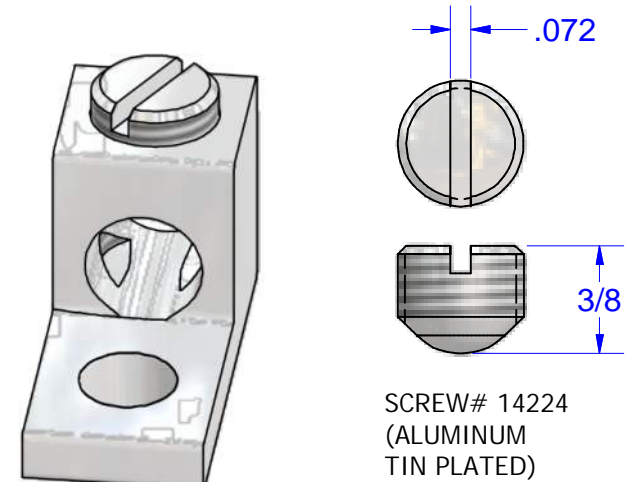
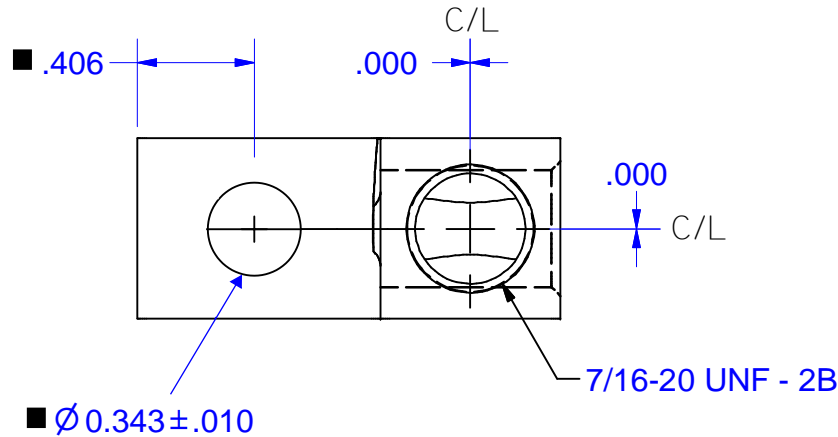

MARKING

S1/0
IHI
1/0-14
CU9AL
UL Logo
CSA Logo

NOT FOR USE WHERE FAILURE CREATES A HAZARD TO HUMAN HEALTH OR SAFETY. ALL PRODUCTS ARE SUBJECT TO THIS FULL DISCLAIMER: <http://www.ihconnectors.com/disclaimer.html>

FOR FURTHER INFORMATION ON THE PROPER USE OF THIS PRODUCT IN SPECIFIC APPLICATIONS SEE <http://www.ihconnectors.com/GuideToFlexFlexibleFineStrandedWireCableMechanicalLugsFAQ.html>
<http://www.ihconnectors.com/Technical-Data-Installation.htm>

FLEX WIRE 1-8 AWG

THIS DRAWING AND DESIGN ARE THE PROPERTY OF INTERNATIONAL HYDRAULICS, INC., CLEVELAND, OHIO, AND MAY NOT BE DUPLICATED, USED FOR THE BASIS OF DESIGN OR MANUFACTURE WITHOUT THE WRITTEN PERMISSION OF INTERNATIONAL HYDRAULICS, INC., CLEVELAND, OHIO.		INTERNATIONAL HYDRAULICS, INC.		
GENERAL TOLERANCES $\pm .015$ ($\pm 0,038$)		TITLE: S1/0-34-41 5/16" 8mm BOLT LUG		
MATERIAL: 6061-T6 (EXT1075)	SIZE:	DRAWN BY: CDMR	DWG NO.: S1-0-34-41(SALES)	REV:
FINISH: TIN PLATE EMS	DATE: 1-29-2018	THIS IS A CAD DRAWING, DO NOT MANUALLY REVISE		